

Predistortion Linearizers Can Give TWTAs an Effective 4X Power Increase with Multicarrier Traffic.

LINEARIZER

Ka Band

BAFL-28000G.d



- Wide Dynamic Range
- Available from 26-32 GHz
- Easy to Align
- For TWTAs and Klystrons
- Full digital control (analog option available)
- Wide range temperature compensation
- Compact Design

BAFL - 28000G.d **OUTLINE SPECIFICATIONS**

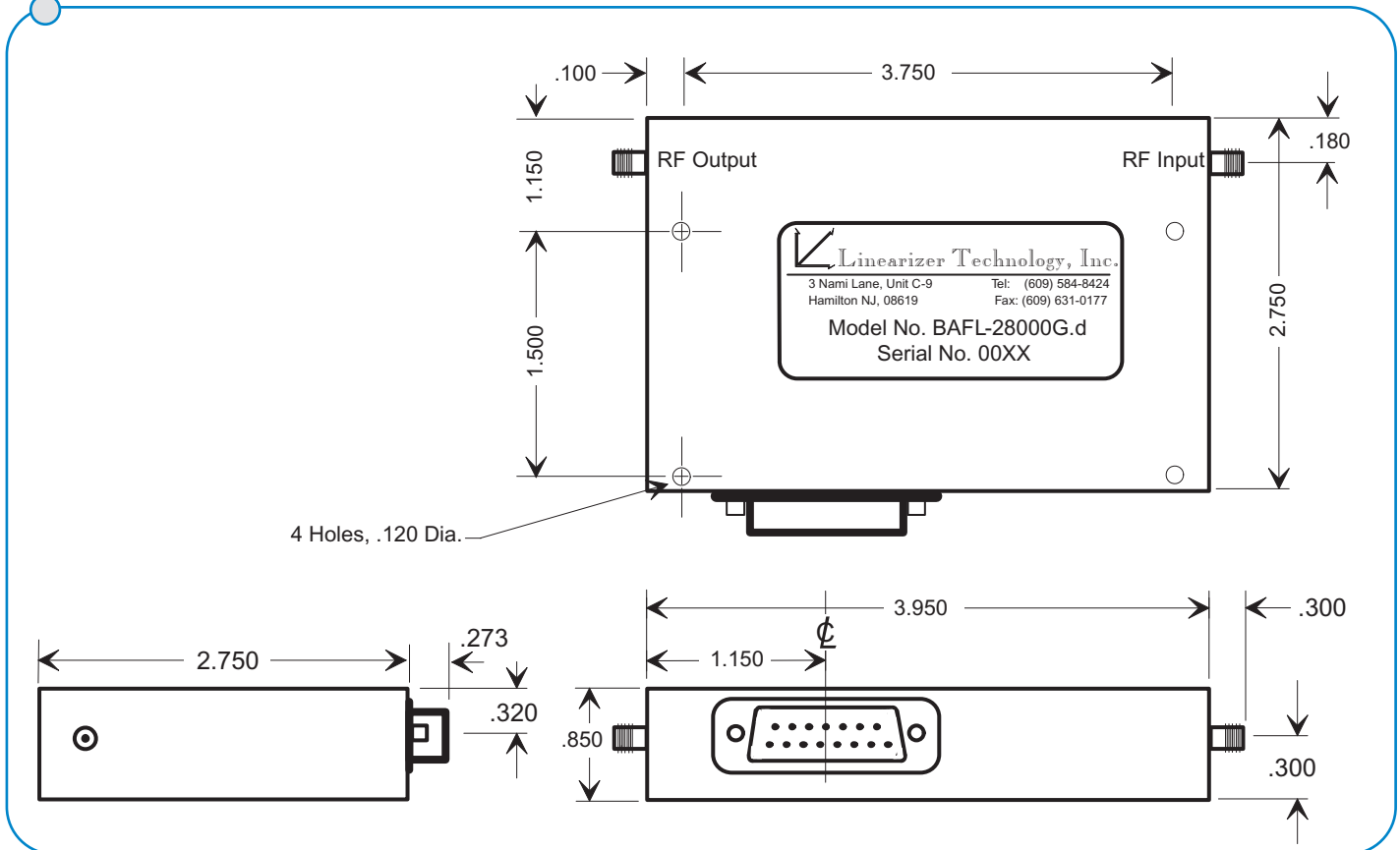

1. Frequency Ranges						Standard : 1 GHz BW 26 to 32 GHz
						Optional : > 2 GHz continuous BW available
2. Power Level In for TWTA Rated Power						Adj. from -10 dBm to 0 dBm
3. Power Level Out for TWTA Rated Power						Adj. from -8 dBm to +3 dBm (> Available)
4. Output Backoff (From Single Carrier Rated Power)						Min. Carrier to Intermodulation (C/I) Ratio (with TWTA)
	3 dB					> 25 dB
	≥ 4 dB					> 30 dB
5. Gain Flatness						< ± 0.5 dB Over Any 500 MHz
6. Gain Slope						< 0.020 dB/MHz
7. Gain Stability Over Temperature						± 0.5 dB, -20 to +60 ° C
8. Static Phase Shift						< ± 5 degrees to Rated Power (with TWTA)
9. Group Delay						< 1 ns/60 MHz
10. AM/PM Conversion						< 2 deg/dB to Rated Power (with TWTA) (1 deg/dB typical)
11. Spurious/Noise						< -135 dBw/4 KHz (at 0 dB gain)
12. Input/Output VSWR						< 1.5
13. Power						+15 Volts dc, < 350 mA
14. RF Interface						2 K Female Connectors

BAFL - 28000G.d **FUNCTIONAL BLOCK DIAGRAM**

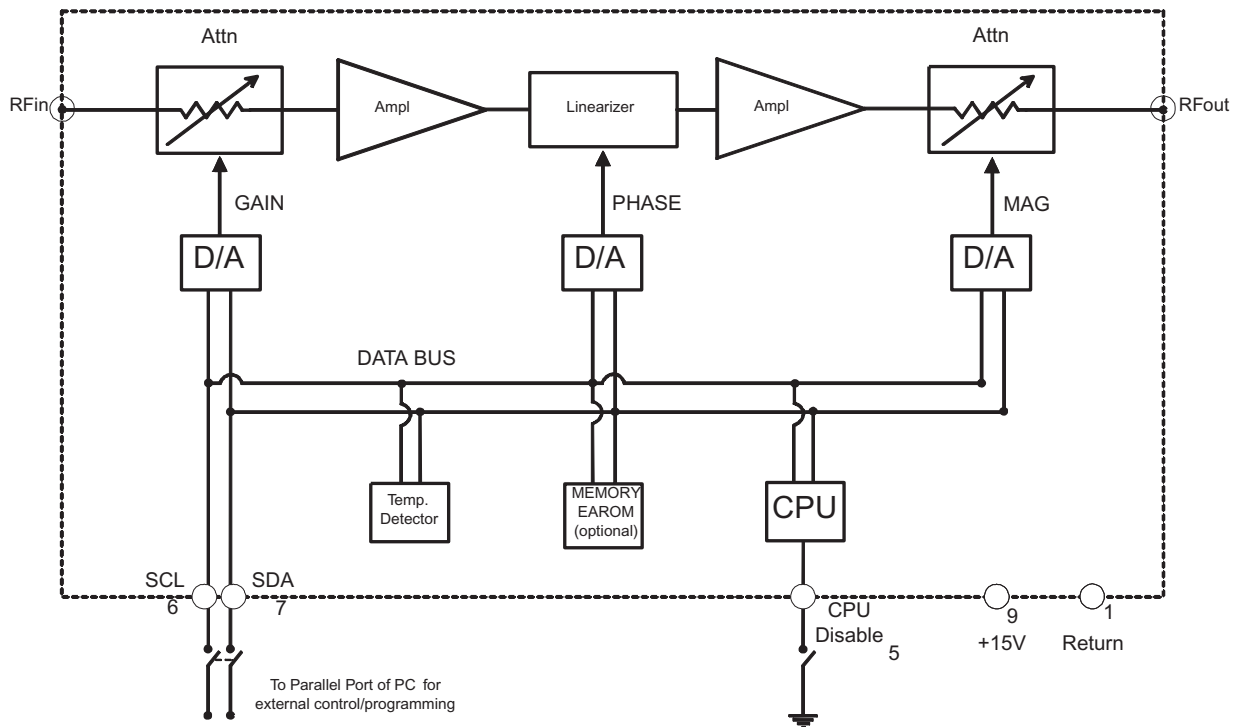

DB15P Pin #	Pin Designation	DB15P Pin #	Pin Designation	DB15P Pin #	Pin Designation
1	+15 Vdc Input	6	SCL	11	
2		7	SDA	12	
3		8	15 Vdc Return (Ground)	13	
4		9		14	
5		CPU Disable		10	